

## 4 BOUTON ST

**Location** 4 BOUTON ST

**Mblu** 583/Z 10/ / /

**Owner** CONCORD GENERAL MUTUAL

**Assessment** \$3,085,000

**Appraisal** \$3,085,000

**PID** 4466

**Building Count** 1

**Tract #** 1845

**Tract #** 1845-B

**Tract #** 1846-A

**Tract #** 1847

**Tract #** 1845-A

**Tract #** 1847-A +

### Current Value

Appraisal			
Valuation Year	Improvements	Land	Total
2022	\$2,458,900	\$626,100	\$3,085,000

Assessment			
Valuation Year	Improvements	Land	Total
2022	\$2,458,900	\$626,100	\$3,085,000

### Owner of Record

**Owner** CONCORD GENERAL MUTUAL

**Sale Price** \$0

**Co-Owner** INSURANCE CO

**Certificate**

**Address** 4 BOUTON ST

**Book & Page** 1100/0240

CONCORD, NH 03301-5006

**Sale Date** 07/01/1971

### Ownership History

Ownership History				
Owner	Sale Price	Certificate	Book & Page	Sale Date
CONCORD GENERAL MUTUAL	\$0		1100/0240	07/01/1971

### Building Information

#### Building 1 : Section 1

**Year Built:** 1958

**Living Area:** 28,556  
**Replacement Cost:** \$4,268,719  
**Replacement Cost Less Depreciation:** \$2,347,800

### Building Layout

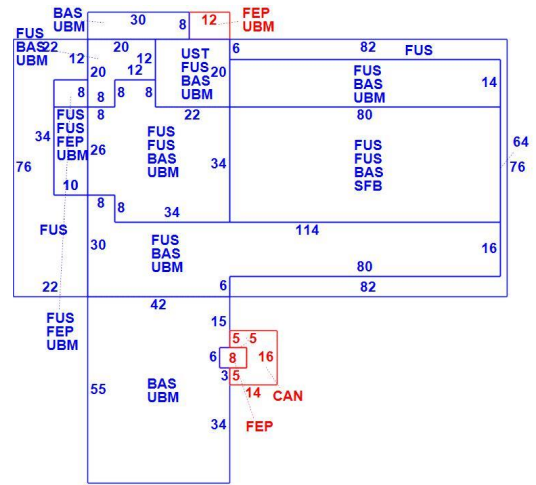

(ParcelSketch.ashx?pid=4466&bid=4666)

Building Attributes	
Field	Description
Style:	Office Bldg
Model	Commercial
Grade	Good
Stories:	3
Occupancy	1.00
Exterior Wall 1	Glass/Thermo.
Exterior Wall 2	Stone/Masonry
Roof Structure	Flat
Roof Cover	T&G/RUBBER
Interior Wall 1	Drywall/Sheet
Interior Wall 2	
Interior Floor 1	Carpet
Interior Floor 2	
Heating Fuel	Oil
Heating Type	Hot Water
AC Type	Central
Struct Class	
Bldg Use	OFFICE BLD MDL-94
Total Rooms	
Total Bedrms	00
Total Baths	2
Heat/AC	HEAT/AC SPLIT
Frame Type	STEEL
Baths/Plumbing	AVERAGE
Ceiling/Wall	SUS-CEIL & WL
Rooms/Prtns	AVERAGE
Wall Height	12.00
% Comn Wall	0.00
Trend	

Building Sub-Areas (sq ft)			Legend
Code	Description	Gross Area	Living Area
FUS	Upper Story, Finished	15,536	15,536
BAS	First Floor	10,844	10,844
SFB	Base, Semi-Finished	2,720	2,176
CAN	Canopy	194	0
FEP	Porch, Enclosed, Finished	484	0
UBM	Basement, Unfinished	8,560	0
UST	Utility, Storage, Unfinished	440	0
		38,778	28,556

### Extra Features

Extra Features					Legend
Code	Description	Size	Value	Assessed Value	Bldg #
ELP2	ELEV PAS 4+ ST	1.00 UNITS	\$40,600	\$40,600	1
CFL2	COMP FLR W/HALON	600.00 S.F.	\$15,800	\$15,800	1
ELPS	ELEV PAS STOPS	4.00 #STOPS	\$11,900	\$11,900	1

## Land

---

Land Use		Land Line Valuation	
Use Code	3400	Size (Acres)	1.72
Description	OFFICE BLD MDL-94	Assessed Value	\$626,100
Zone	IS	Appraised Value	\$626,100
Neighborhood	0406		
Category			

## Outbuildings

---

Outbuildings	Legend
No Data for Outbuildings	