



City of Concord
 37 Green St
 Concord, NH 03301
 www.concordnh.gov

Permit

Permit NO. **SP-0379-2024**
 Permit Type: **CD - Sign or Awning**
 Work Classification: **Sign**
 Permit Status: **Fees Paid**

Issue Date: _____ Expiration: _____

Location Address

Parcel Number

92 Manchester St, Concord, NH

8859

Contacts

Jeremy Martinson (802)309-9551	Owner	Spectrum Signs 95 Eddy Road 101, Manchester, NH 03102 (603)657-7079	Applicant jilian@spectrumsigns.com
-----------------------------------	--------------	---	--

Description: Window graphics for corner office

Valuation: \$0.00
Total Sq Feet: 0.00

Inspection Requests:
 603-225-8580

Fees	Amount
CD - Application for Sign	\$30.00
CD - Sign application PB review	\$30.00
CD - Sign Permit Fee SF Cost	\$58.21
Total:	\$118.21

Payments	Amt Paid
Total Fees	\$118.21
Credit Card	\$118.21
Amount Due:	\$0.00

Available Inspections:	
Inspection Type	
Zoning Code Enforcement	0
CD - Final Sign	180

Applicant certifies that all the information given is correct and true and that all work performed will comply with applicable City of Concord and State of New Hampshire, Building and Fire Codes, Ordinances, Laws and Regulations.

Additional Information

Sign Dimensions: 69"X54"
Total Square Feet: 25.87
Is this Sign:: New
Is this sign illuminated?: No
If Yes, pick one: N/A
Sign Projects over Public Right-of-Way: No
How many feet over public right-of-way: 0
SignPermitAddtlInfo: CONDITIONS OF PERMIT • If a sign projects over a sidewalk or public way, it is mandatory for the owner to furnish a Certificate of Insurance in an amount not less than \$1,000,000, indemnifying the City of Concord against any form of liability. The policy shall provide for advance notification to the Code Administrator in the event of cancellation. If the policy should lapse or be canceled, the owner shall remove the sign immediately. • The Code Administrator or his authorized agent may revoke this permit at any time. • No portable signs shall be placed in the public right of way. • All signs shall conform to all requirements of the Zoning Ordinance for the district in which it is located. • All signs must be constructed of materials and methods conforming to the minimum standards of the City of Concord Building Code. • All signs which are illuminated or supplied with electric power must be UL listed and installed in accordance with the City of Concord Electrical Code and shall require separate electrical permits. • Sign permits are not transferrable in case of change of ownership, relocation, or alteration of size or structure.
Zoning District: CH

Issued By: Brian Tremblay

Date

Window Perf- Front



Client
AAMCO

FACE: DIGITALLY PRINTED WINDOW PERF

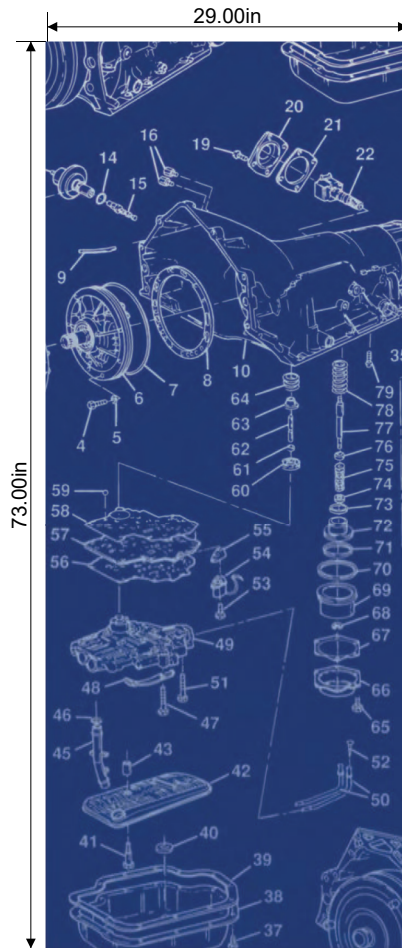
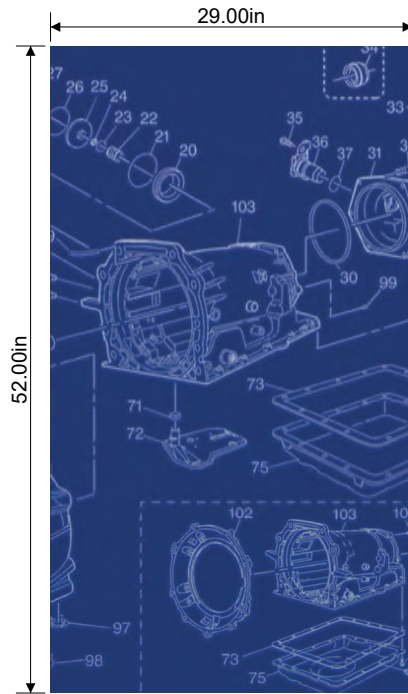

1/10 SCALE

Design Concept Only - Final product may vary based on Fabrication and Installation Requirements

 **SPECTRUM**
SIGNS & GRAPHICS
We Are Visual.
The Visual Communication Experts
603.657.7079
97 EDDY RD. MANCHESTER, NH 03102

This document and information contained herein are exclusive property of spectrum/printing/communication, reproduction, or other uses are prohibited except with written authorization given in connection with company business. It is the customers responsibility to proofread all drawings for spelling, grammar, and layout. Common law copyright is claimed as of the date completed.

Rev#	Revision Notes	DATE	BY
0	Initial sketch	09/17/2024	JD
3	revision	10/1/2024	BTM
File name: AAMCO-WindowPer100p_1024 3.AI			

Customer: AAMCO
Contact Name: Nick Jarvis
Contact Tel:
Site Address: 92 Manchester Street,
Concord NH

Job#: XXXX
Designer: Janaki D/BTM
Date: 10/01/2024
Page: 1

Window Perf- Side



Client
AAMCO

FACE: DIGITTALY PRINTED WINDOW PERF

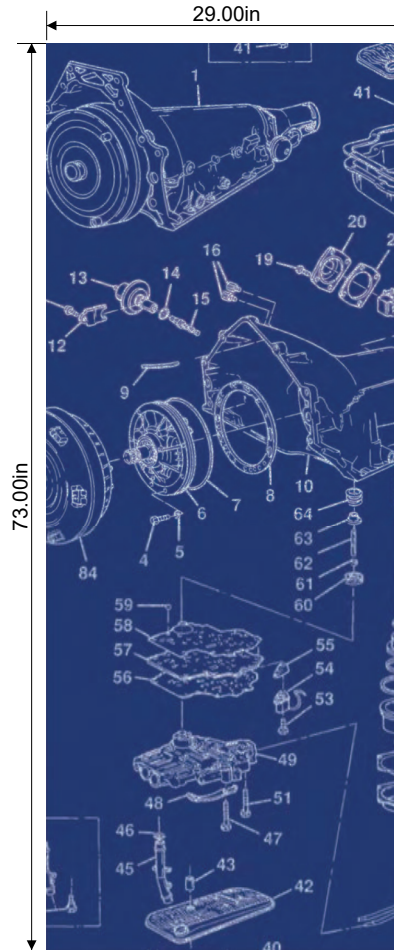
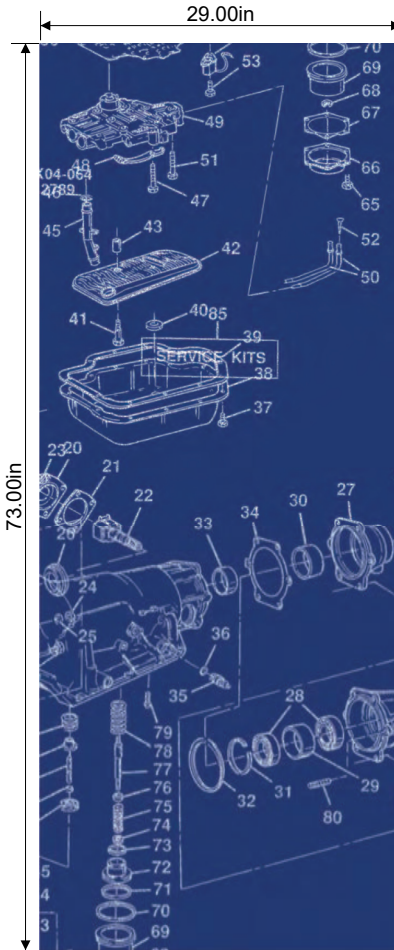
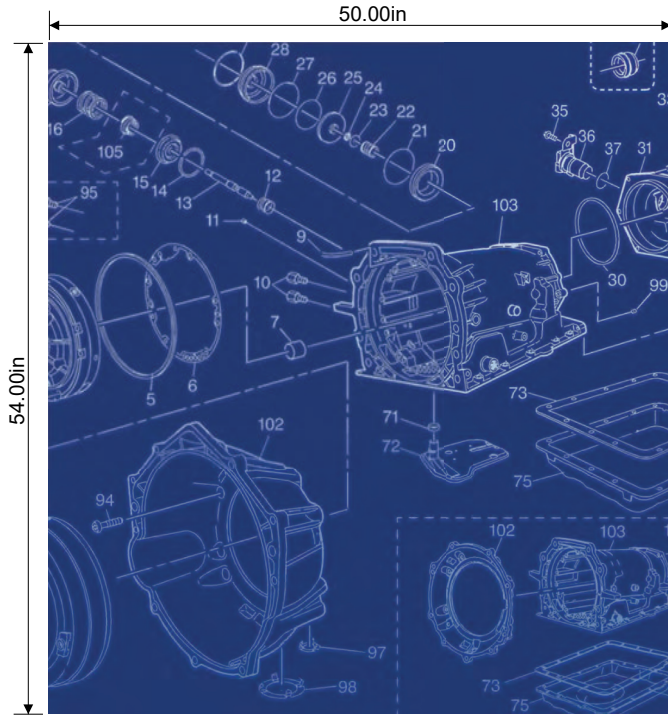

Design Concept Only - Final product may vary based on Fabrication and Installation Requirements

SPECTRUM
SIGNS & GRAPHICS
We Are Visual.
603.657.7079
97 EDDY RD. MANCHESTER, NH 03102

This document and information contained herein are exclusive property of spectrum/printing; communication, reproduction, or other uses are prohibited except with written authorization given in connection with company business. It is the customer's responsibility to proofread all drawings for spelling, grammar, and layout. Common law copyright is claimed as of the date completed.

Rev#	Revision Notes	DATE	BY
0	Initial sketch	09/17/2024	JD
3	revision	10/1/2024	BTM

File name: AAMCO-WindowPerf100p_1024 3.AI

Customer: AAMCO
Contact Name: Nick Jarvis
Contact Tel:
Site Address: 92 Manchester Street,
Concord NH

Job#: XXXX
Designer: Janaki D/BTM
Date: 10/01/2024
Page: 2



Design Concept Only - Final product may vary based on Fabrication and Installation Requirements.

 **SPECTRUM**
SIGNS & GRAPHICS
We Are Visual.
The Visual Communication Experts
603.657.7079
97 EDDY RD. MANCHESTER, NH 03102

This document and information contained herein are exclusive property of spectrum/signs & graphics. Communication, reproduction, or other uses are prohibited except with written authorization given in connection with company business. It is the customer's responsibility to proofread all drawings for spelling, grammar, and layout. Common law copyright is claimed as of the date completed.

Rev#	Revision Notes	DATE	BY
0	Initial sketch	09/17/2024	JD
3	Revision	10/1/2024	BTM
File name: AAMCO-WindowPer100p_1024 3.AI			

Customer: AAMCO
Contact Name: Nick Jarvis
Contact Tel:
Site Address: 92 Manchester Street,
Concord NH

Job#: XXXX
Designer: Janaki D/BTM
Date: 10/01/2024
Page: 3