

Z:\PROJECTS\2025\250093\ASSOCIATED ENTERPRISES - 103 NORTH STATE STREET, CONCORD, NH\CDR\DWG\250093-103.DWG

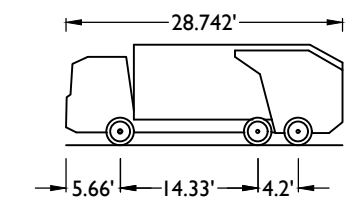

**FRONT LOADING REFUSE VEHICLE**

OVERALL LENGTH	28.742 FT
OVERALL WIDTH	8.000 FT
OVERALL BODY HEIGHT	13.500 FT
MIN BODY GROUND CLEARANCE	1.311 FT
TRACK WIDTH	8.000 FT
LOCK-TO-LOCK TIME	6.00 s
CURB TO CURB TURNING RADIUS	34.000 FT

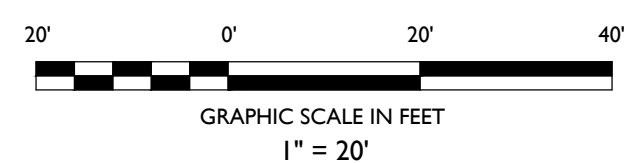
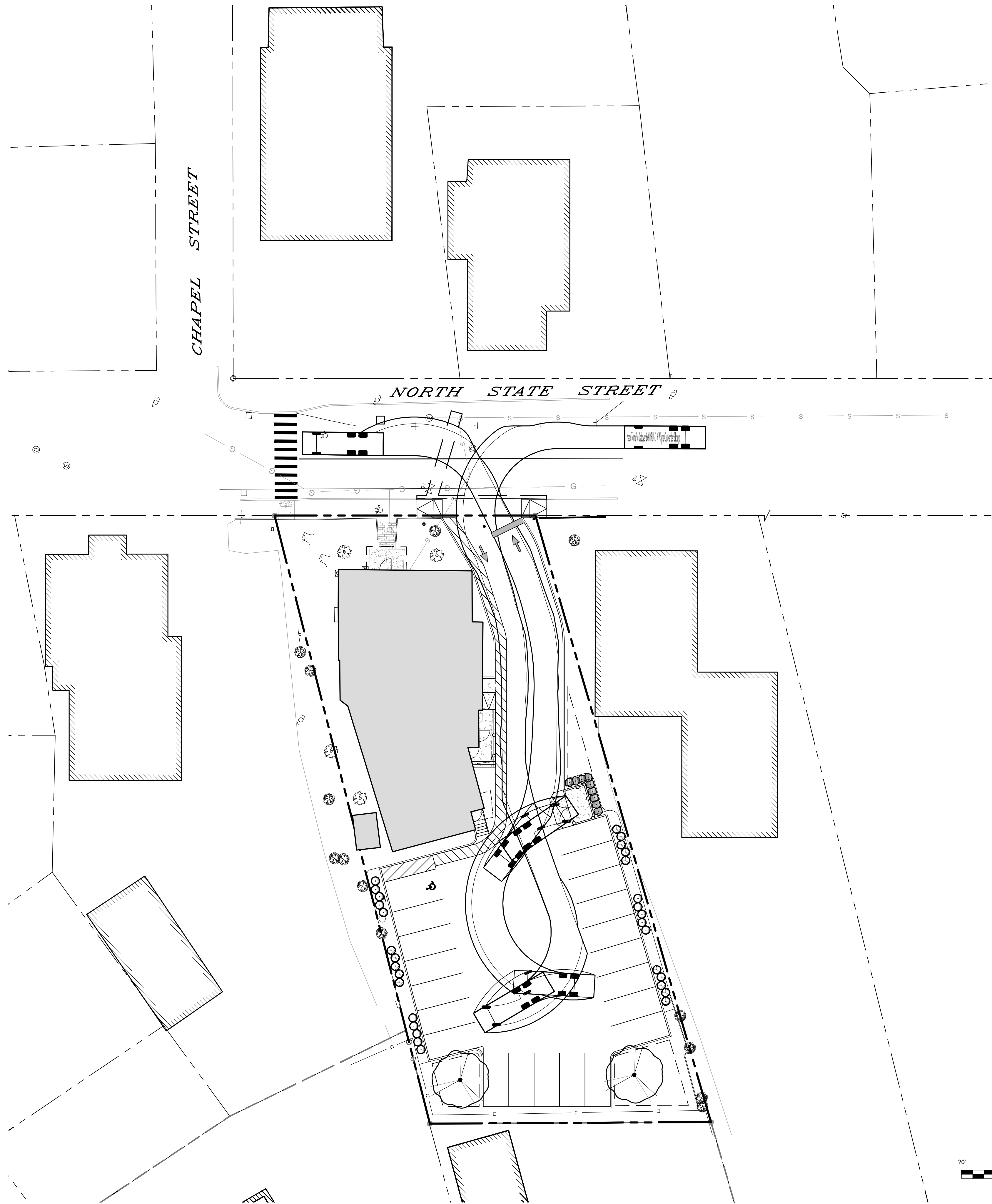
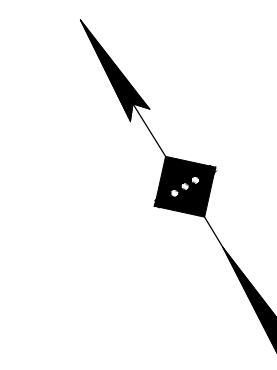
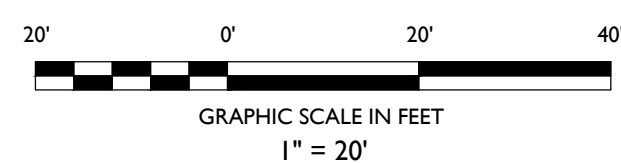
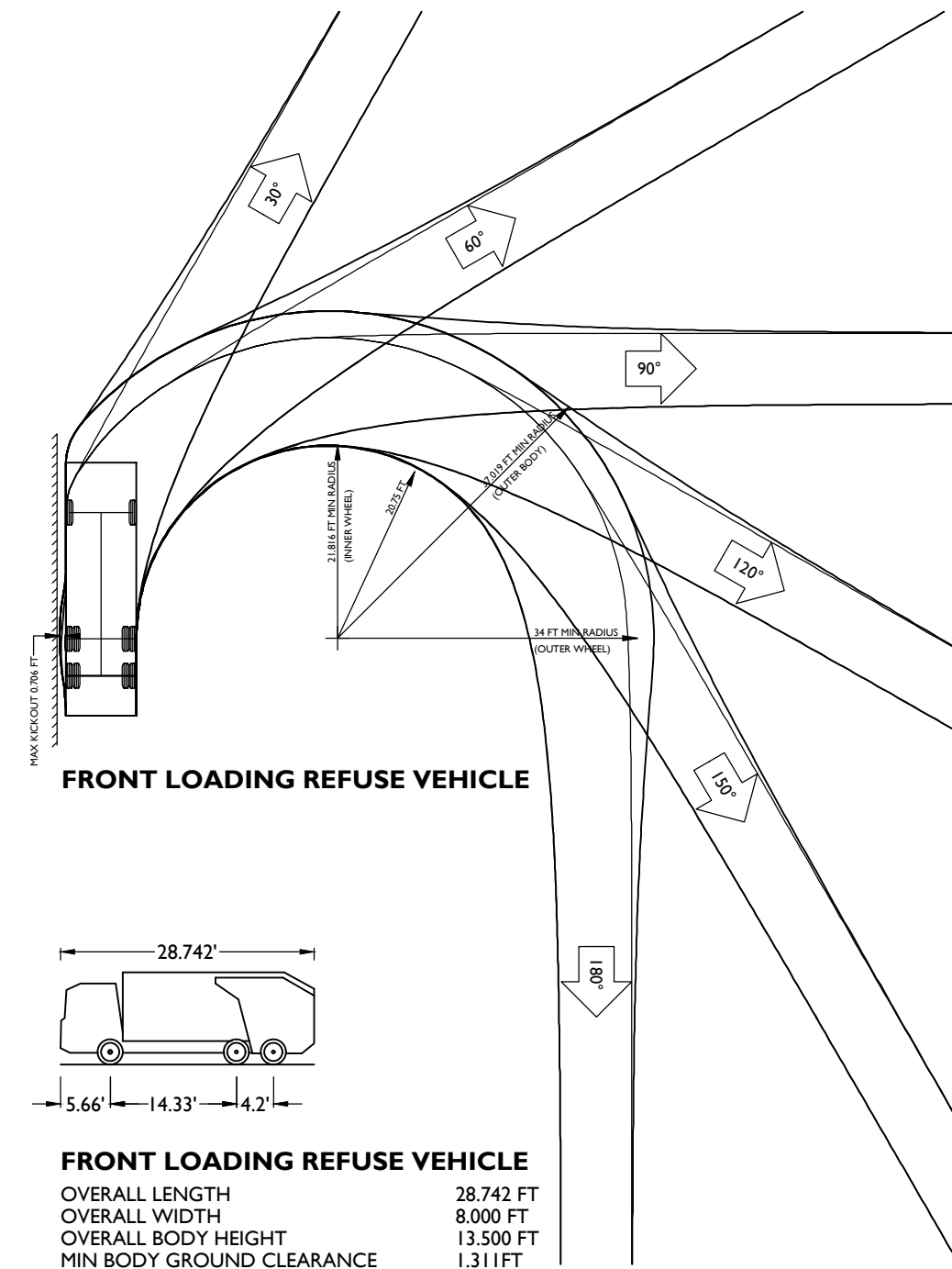

**TRUCK MOVEMENT EXHIBIT**

**PROPOSED MULTI-FAMILY  
RESIDENTIAL ADAPTIVE  
REUSE**

**APPLICANT &  
OWNER**  
ASSOCIATED ENTERPRISES, INC.  
136 N MAIN STREET, SUITE 2  
CONCORD, NEW HAMPSHIRE  
03301

MAP 6414, BLOCK Z, LOT 1  
103 NORTH STATE STREET  
CITY OF CONCORD  
MERRIMACK COUNTY, NEW HAMPSHIRE

JOSHUA H. KLINE, P.E.  
NEW HAMPSHIRE LICENSE No. 16330  
LICENSED PROFESSIONAL ENGINEER



SCALE: 1" = 20' PROJECT ID: BOS-250093

TITLE:  
**VEHICLE MANEUVERING  
EXHIBIT (TRASH)**

DRAWING:

**1 OF 1**



Rutherford, NJ · New York, NY · Salem, MA  
Princeton, NJ · Tampa, FL · Birmingham, MI  
www.stonefielddesign.com

120 Washington Street, Suite 201, Salem, MA 01970  
Phone 617.203.2076

**NOT APPROVED FOR CONSTRUCTION**

ISSUE	DATE	BY	DESCRIPTION
01	04/15/2024	NS	ISSUED FOR MUNICIPAL RESUBMISSION